

ATELIER *delle*
FINITURE

BOX DOCCIA

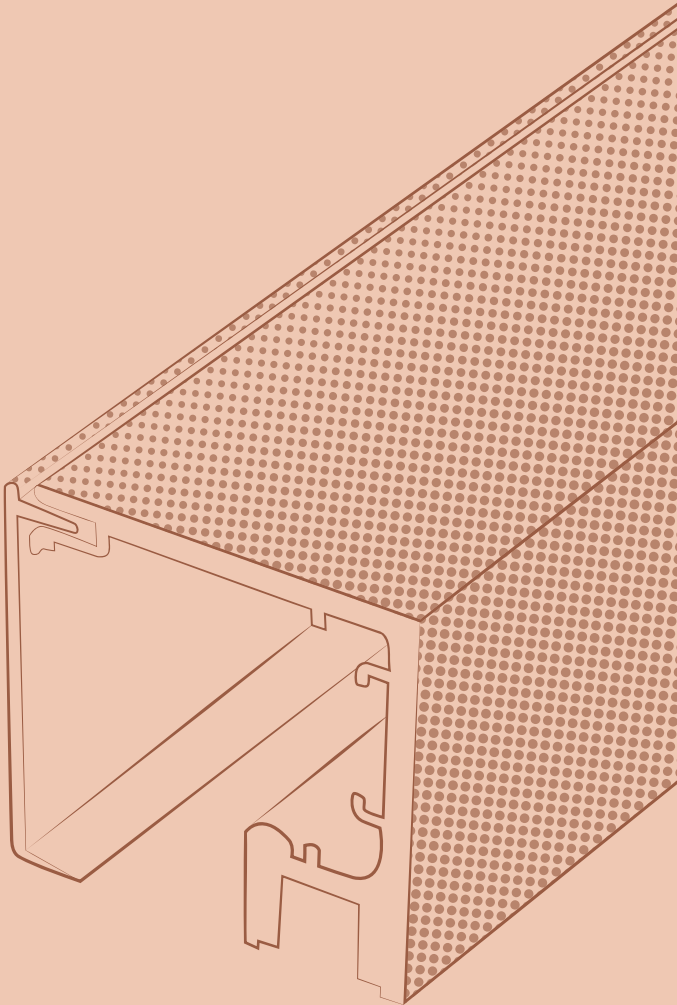

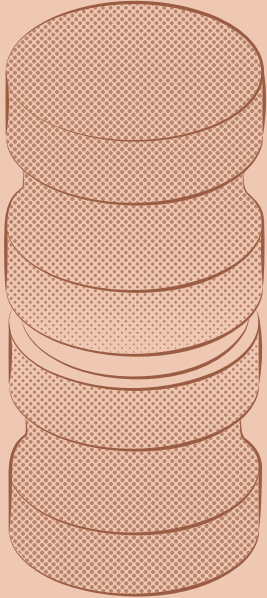
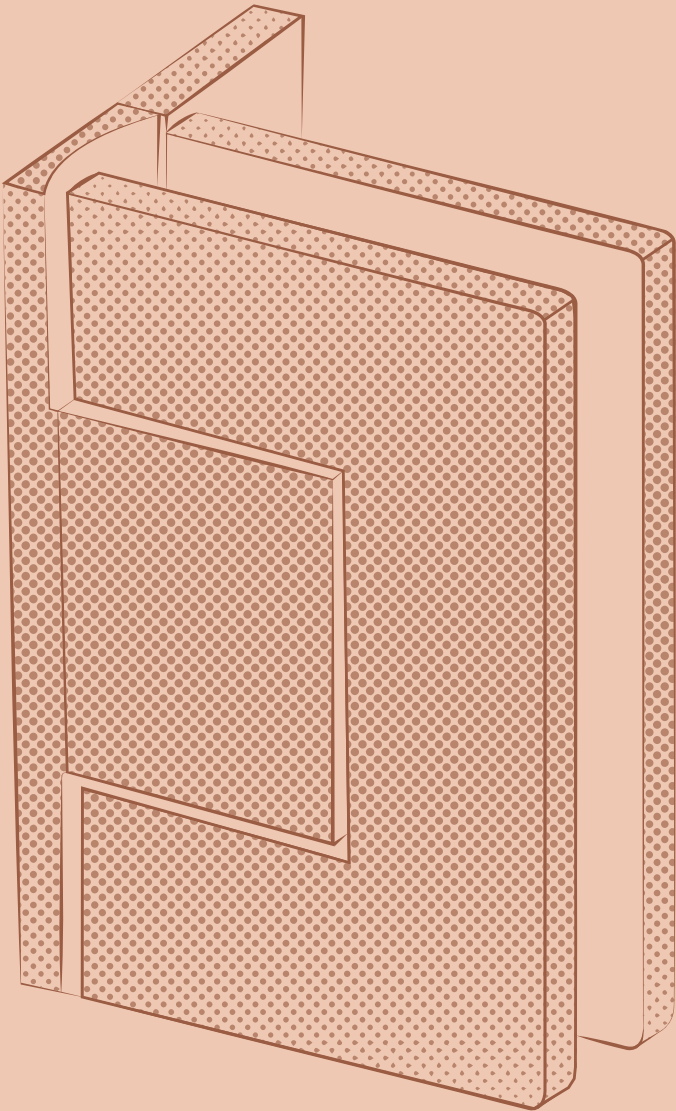

ATELIER *delle* FINITURE

Da una sola materia prima, l'alluminio, al prodotto finito ottenuto con un unico procedimento di colorazione. Nasce ATELIER DELLE FINITURE, che offre numerosi vantaggi estetici e pratici:

- armonia visiva
- maggiore percezione dello spazio
- maggiore valore estetico e percepito
- facilità di manutenzione.

From a single raw material–aluminum–to the finished product, achieved through a single coloring process. This is the origin of ATELIER DELLE FINITURE, which offers numerous aesthetic and practical advantages:

- *visual harmony*
- *greater perception of space*
- *increased aesthetic and perceived value*
- *ease of maintenance*

Von einem einzigen Rohmaterial – Aluminium – bis zum Endprodukt, das durch ein einziges Farbverfahren entsteht.

So entsteht das ATELIER DELLE FINITURE, das zahlreiche ästhetische und praktische Vorteile bietet:

- *visuelle Harmonie*
- *besseres Raumempfinden*
- *höherer ästhetischer und wahrgenommener Wert*
- *einfache Wartung*

DALL'ALLUMINIO ALL'ATELIER DELLE FINITURE

FROM ALUMINUM TO THE ATELIER DELLE FINITURE
VOM ALUMINIUM ZUM ATELIER DELLE FINITURE



ATELIER *delle*
FINITURE



- La collezione è ottenuta mediante la fresatura con CNC (controllo numerico computerizzato), processo sottrattivo, in cui il materiale viene rimosso da un blocco grezzo con utensili da taglio rotanti per ottenere la forma desiderata.

Fresare l'alluminio può costare fino a dieci volte di più rispetto alla pressofusione della zama perché:

- l'alluminio, è generalmente più costoso della zama;
- la lavorazione richiede più tempo e macchinari specifici;
- si generano più scarti;
- è ideale per serie in quantità limitata;
- ogni dettaglio deve essere pensato in anticipo; se si commettono errori sulle misure i componenti non coincidono e gli elementi attivi, come le cerniere, non funzionano.

- The collection is made using CNC (computer numerical control) milling, a subtractive process where material is removed from a raw block using rotating cutting tools to achieve the desired shape.

Milling aluminum can cost up to ten times more than die-casting zamak because:

- aluminum is generally more expensive than zamak;
- the process requires more time and specialized machinery;
- it generates more waste;
- it is ideal for small production runs;
- every detail must be planned in advance; if measurements are wrong, the parts won't match and active components, such as hinges, will not work.

- Die Kollektion wird durch CNC-Fräsen (computerisierte numerische Steuerung) hergestellt – ein subtraktives Verfahren, bei dem Material aus einem Rohblock mit rotierenden Schneidwerkzeugen entfernt wird, um die gewünschte Form zu erhalten.

Das Fräsen von Aluminium kann bis zu zehnmal teurer sein als das Druckgießen von Zamak, weil:

- Aluminium im Allgemeinen teurer ist als Zamak;
- der Bearbeitungsprozess mehr Zeit und spezielle Maschinen erfordert;
- mehr Abfall entsteht;
- es ideal für Kleinserien ist;
- jedes Detail im Voraus durchdacht werden muss; bei Maßfehlern passen die Komponenten nicht zusammen und aktive Elemente wie Scharniere funktionieren nicht.

TIPOLOGIE DI BOX DOCCIA

TYPES OF SHOWER ENCLOSURES

AUSWAHL VON DUSCHKABINEN

PORTA BATTENTE

pag. 78

HINGED DOOR

DREHTÜR

VANITY

B-751 / B-752 / B-753 / B-196

POR-0408 / SQUARE15

PORTA SCORREVOLE

pag. 78

SLIDING DOOR

SCHIEBETÜR

BX-5000

BX-4000

WALK-IN

pag. 78

B-220

B-136 / B-137 / B-138

P-017

BX-PT-C58 / BX-PT-C56

GAMMA FINITURE PROFILI IN ALLUMINIO

FINISHING RANGE ALUMINUM PROFILES

OBERFLÄCHEN-SORTIMENT ALUMINIUMPROFILE

ATELIER *delle*
FINITURE



<p>CR Cromo Lucido <i>Polished Chrome</i> <i>Chrom Glänzend</i></p>	<p>IX / XO Effetto Inox Satinato <i>Inox Effect</i> <i>Inox Effekt</i></p>	<p>NO Nero Opaco <i>Matt Black</i> <i>Schwarz Matt</i></p>	<p>CF Canna di Fucile <i>Gunmetal Grey</i> <i>Tief Schwarz Matt</i></p>	<p>BV Bronzo Scuro <i>Dark Bronze</i> <i>Dunkelbraun</i></p>	<p>OL Ottone Lucido <i>Polished Brass</i> <i>Messing Poliert</i></p>	<p>OS Oro Satinato <i>Satin Gold</i> <i>Gold matt</i></p>	<p>RM Rame Satinato <i>Satin Copper</i> <i>Kupfer Mat</i></p>	<p>BI Bianco Opaco <i>Matt White</i> <i>Weiss Matt</i></p>
<p>Finitura ottenuta mediante ossidazione anodica <i>Finish by anodic oxidation</i> <i>Oberfläche durch anodische Oxidation</i></p>	<p>Finitura ottenuta mediante ossidazione anodica <i>Finish by anodic oxidation</i> <i>Oberfläche durch anodische Oxidation</i></p>	<p>Finitura ottenuta mediante ossidazione anodica <i>Finish by anodic oxidation</i> <i>Oberfläche durch anodische Oxidation</i></p>	<p>Finitura ottenuta mediante ossidazione anodica <i>Finish by anodic oxidation</i> <i>Oberfläche durch anodische Oxidation</i></p>	<p>Finitura ottenuta mediante verniciatura. <i>Finish by painting</i> <i>Oberfläche durch Lackierung</i></p>	<p>Finitura ottenuta mediante ossidazione anodica <i>Finish by anodic oxidation</i> <i>Oberfläche durch anodische Oxidation</i></p>	<p>Finitura ottenuta mediante ossidazione anodica <i>Finish by anodic oxidation</i> <i>Oberfläche durch anodische Oxidation</i></p>	<p>Finitura ottenuta mediante ossidazione anodica <i>Finish by anodic oxidation</i> <i>Oberfläche durch anodische Oxidation</i></p>	<p>Finitura ottenuta mediante verniciatura. <i>Finish by painting</i> <i>Oberfläche durch Lackierung</i></p>
	<p>NS Nickel Satinato <i>Satin Nickel</i> <i>Ähnlich Edelstahl Matt</i></p> <p>Finitura ottenuta mediante bagno galvanico (minuteria: maniglie, cerniere e barre stabilizzatrici) <i>Finish obtained by galvanic bath (small parts: handles, hinges and stabilizer bracket)</i></p> <p><i>Oberfläche durch Galvanikbad erzielt (Kleinteile: Griffe, Scharniere und Stabilisierungs-Winkel Verstellbar)</i></p>	<p>NV Nero Opaco <i>Matt Black</i> <i>Schwarz Matt</i></p> <p>Finitura ottenuta mediante verniciatura <i>Finish by painting</i></p> <p><i>Oberfläche durch Lackierung</i></p>						

VANITY

ALL-IN-ONE: Vanity ridefinisce il concetto di flessibilità progettuale

ALL-IN-ONE: Vanity redefines the concept of design flexibility

ALL-IN-ONE: Vanity definiert das konzept der design-flexibilität

Panoramica prodotto
Product overview



P782

Listino
Price list



F3637

ATELIER *delle*
FINITURE



VANITY SET 1



VANITY SET 2



VANITY SET 3



VANITY SET 3

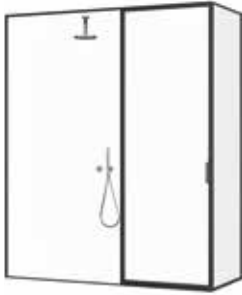

VANITY SET 5

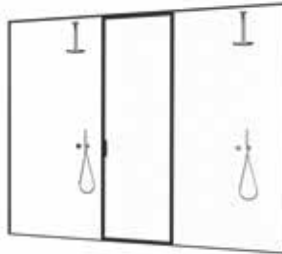

VANITY SET 6

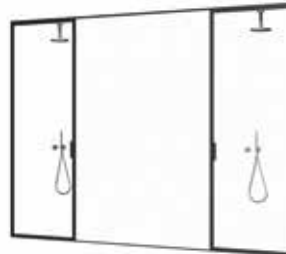

VANITY SET 7



VANITY SET 8



VANITY SET 9

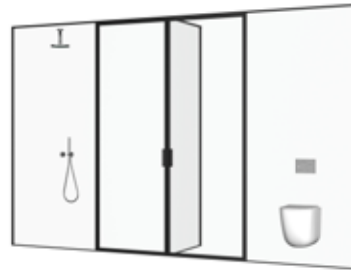

xme705

CR

IX

NO

CF

BV

OL

OS

RM

BI

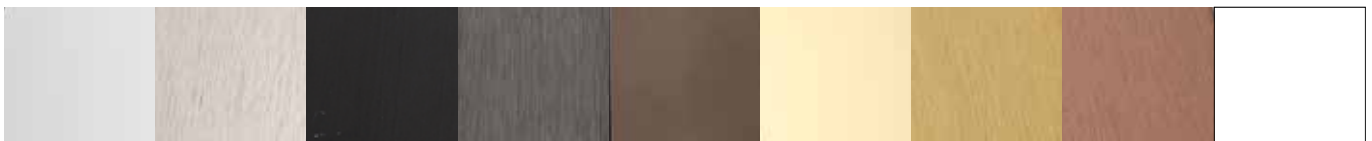

VANITY

CARATTERISTICHE TECNICHE

FEATURES

EIGENSCHAFTEN

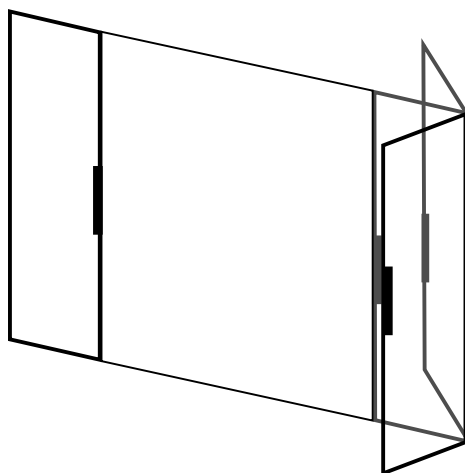

- Apertura sia interna che esterna
- *Inward and outward opening*
- *Beidseitig öffnend*

- Profili perimetrali minimali
- *Minimal perimeter profiles*
- *Minimale Rahmenprofile*



- Cerniera inferiore con movimento saliscendi
- *Bottom hinge with lift-lower function*
- *Unteres Band mit Hebe-Senk Funktion*



- Le guarnizioni magnetiche sono nascoste all'interno dei montanti di battuta
- *The magnetic gaskets are hidden inside the vertical profiles*
- *Die magnetischen Dichtungen sind im Inneren der senkrechten Profile versteckt*



- Profili a parete regolabili
- *Adjustable wall profiles*
- *Verstellbare Wandanschlussprofile*



- Doppia guarnizione inferiore
- *Double bottom gasket*
- *Doppelte Bodendichtung*



- Modulo drenaggio acqua
- *Water drainage module*
- *Wasserentwässerungsmodul*



- Installazione ad altezza libera
- *Free-standing installation*
- *Installation in freier Höhe*



CERNIERE A SCATTO

CLICKING HINGES

SELBSTSCHLIESSENDE BÄNDER

Panoramica prodotto
Product overview



P623

Listino
Price list



F2627

ATELIER *delle*
FINITURE





CR

B-751

- Cerniera a scatto vetro muro regolabile posizione "0", senza viti a vista. Materiale: alluminio.
- Glass to wall double action clicking hinge, no visible screws. "0" position adjustable. Material: aluminum.
- Pendeltürband Glas-Wand ohne sichtbare Schrauben, mit verstellbarer Nulllagenstellung. Material: Aluminium.



CR

B-752

- Cerniera a scatto regolabile vetro/vetro senza viti a vista. Materiale: alluminio.
- Adjustable glass/glass clicking hinge, no visible screws. Material: aluminum.
- Pendeltürband Glas-Glas ohne sichtbare Schrauben, mit verstellbarer Nulllagenstellung. Material: Aluminium.



CR

B-753

- Cerniera a scatto regolabile vetro/vetro 90°, senza viti a vista. Materiale: alluminio.
- Adjustable 90° glass to glass double action clicking hinge, no visible screws. Material: aluminum.
- Pendeltürband Glas-Glas 90°, mit verstellbarer Nulllagenstellung ohne sichtbare Schrauben. Material: Aluminium.



STAFFA ANGOLARE STABILIZZATRICE

ADJUSTABLE ANGLE STABILIZER BRACKET
STABILISIERUNGS-WINKEL VERSTELLBAR

Panoramica prodotto
Product overview



P795

Listino
Price list



F3663

ATELIER *delle*
FINITURE

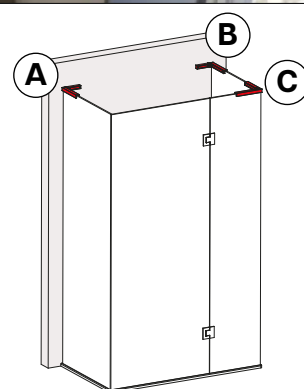
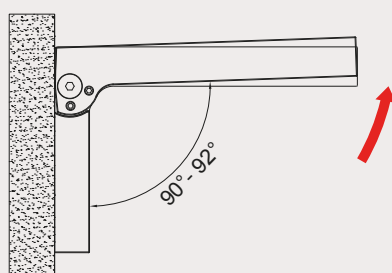
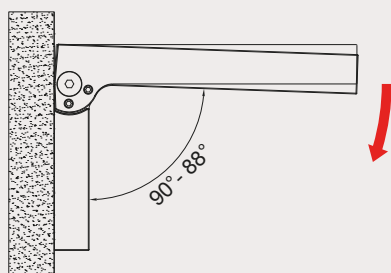

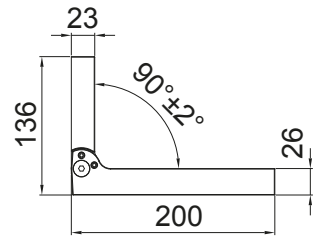

B-428-SX

- Staffa angolare stabilizzatrice muro-vetro, regolabile, sinistra, per vetro 8-10 mm
- Stabilizer angle bracket wall-glass, left version, adjustable, for glass 8-10 mm
- Stabilisierungs-Winkel Wand-Glas links, verstellbar, für Glas 8-10 mm

B-428-DX

- Staffa angolare stabilizzatrice muro-vetro, regolabile, destra, per vetro 8-10 mm
- Stabilizer angle bracket wall-glass, right version, adjustable, for glass 8-10 mm
- Stabilisierungs-Winkel Wand-Glas rechts, verstellbar, für Glas 8-10 mm

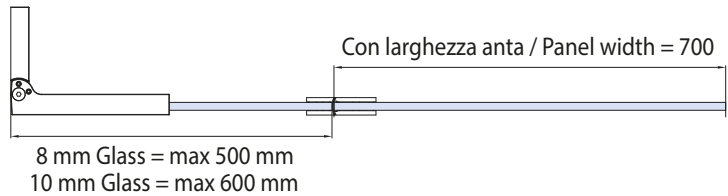
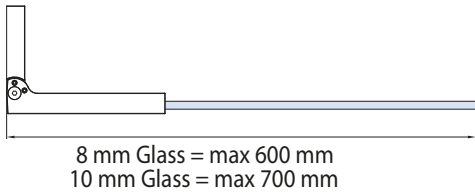
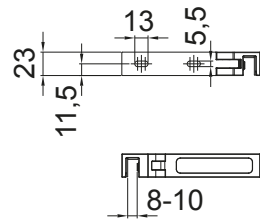

xme728-a



B-429

- Staffa angolare stabilizzatrice vetro-vetro, fissa, per vetro 8-10 mm
- Stabilizer angle bracket glass-glass, fixed, for glass 8-10 mm
- Stabilisierungs-Winkel Glas-Glas, für Glas 8-10 mm

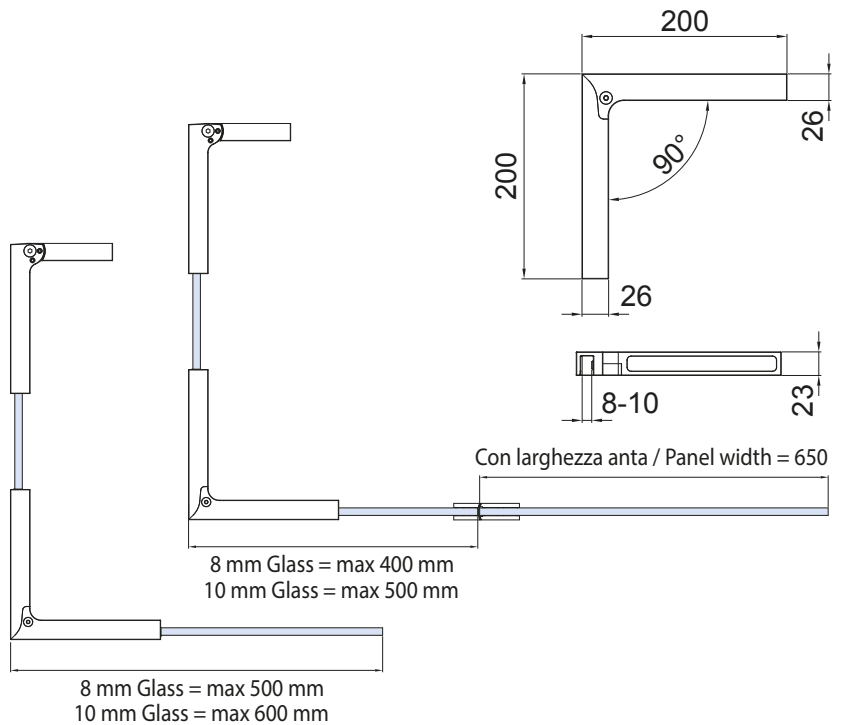

xme728-a



BX-5000+COLORS



40 Kg

- Senza lavorazione vetro
- Without glass preparation
- Ohne Glasbearbeitung

Panoramica prodotto
Product overview



P672

Listino
Price list



F3059

MyMetalglas



ATELIER *delle*
FINITURE



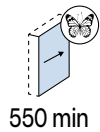
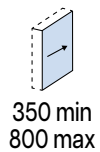
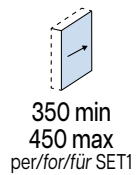
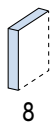
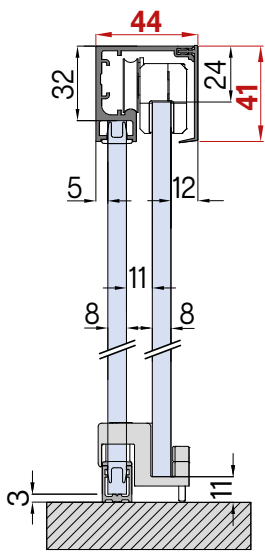

BX-5000-SET1

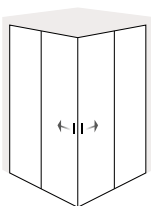

BX-5000-SET2

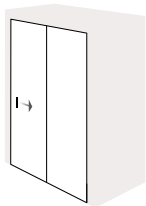

BX-5000-SET3

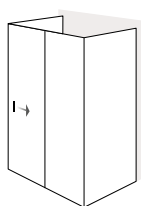

BX-5000-SET4

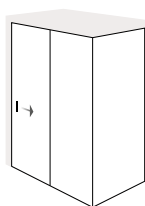

BX-5000-SET5

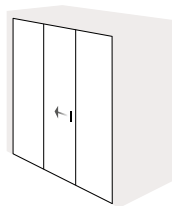

BX-5000-SET6

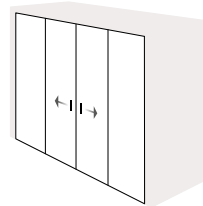

xme628

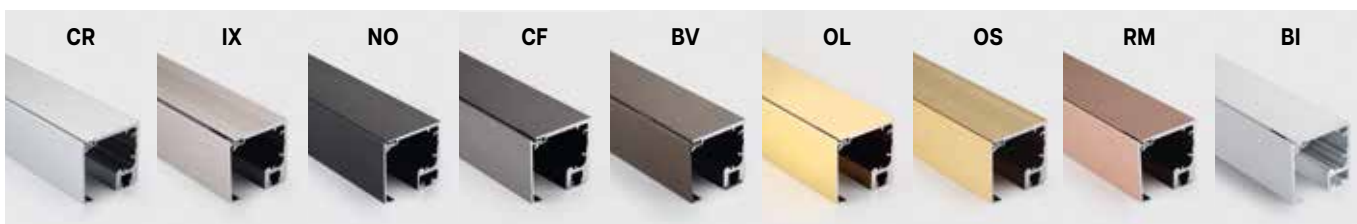

BX-4000+COLORS

40 Kg

Panoramica prodotto
Product overview



P6

Listino
Price list



F1818

MyMetalglas



ATELIER *delle*
FINITURE



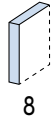
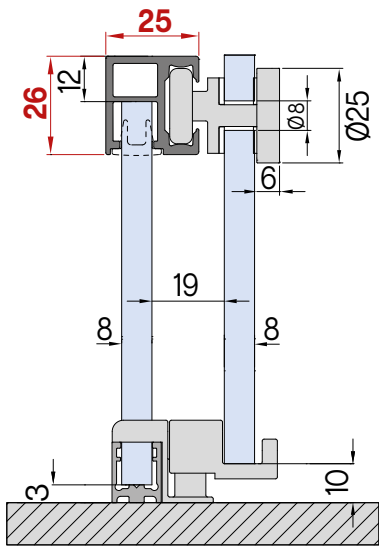

350 min
490 max
per/for/für SET1

550 min
750 max

BX-4000-SET1

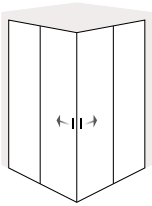

BX-4000-SET2

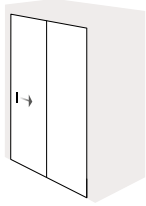

BX-4000-SET3

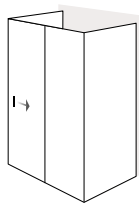

BX-4000-SET4

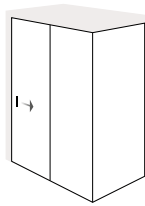

BX-4000-SET5

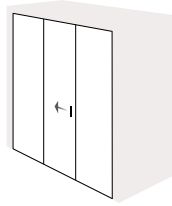

BX-4000-SET6

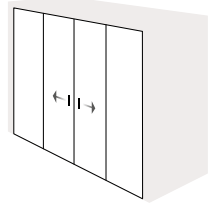

xme512a

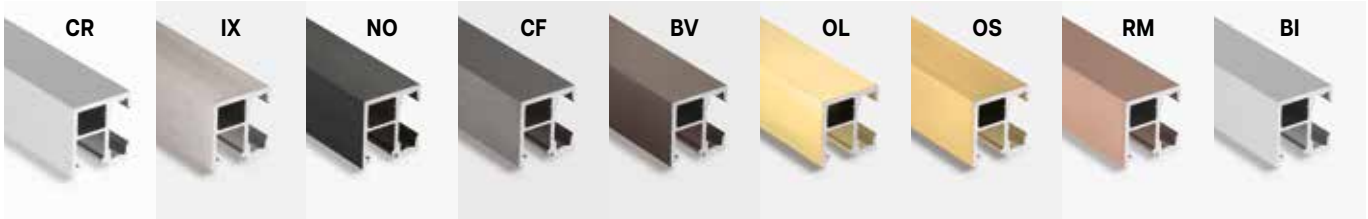



P798



F3664

ATELIER *delle*
FINITURE





B-220

- Barra di supporto snodata riducibile a piacere muro/vetro.
- Square adjustable support bar wall/glass, cuttable to size.
- Eckige Stabilisationsstange Wand/Glas, beliebig Kürzbar.

ART.	Length	Fin
B-220	1200 mm	CR - NS - NO
B-220	1500 mm	CF - BV - OL - OS - RM - BI

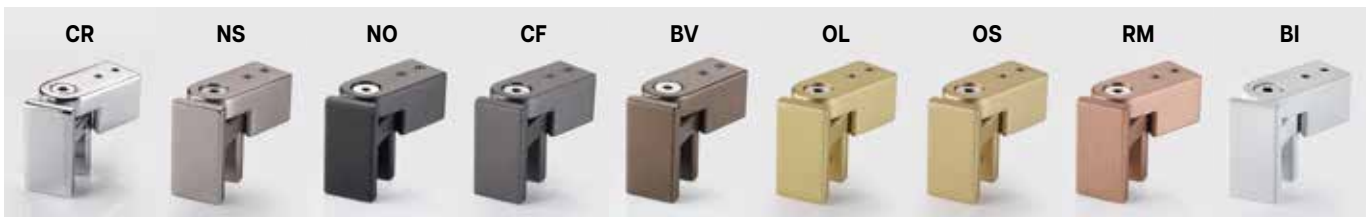
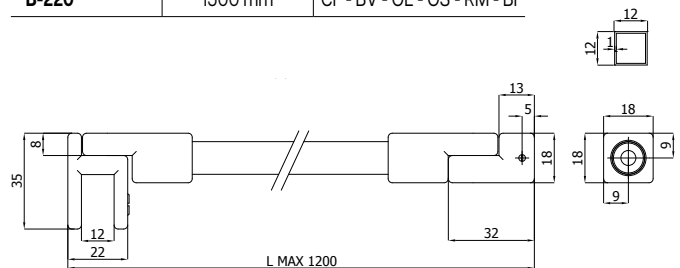

B-223

- Barra centrale quadra riducibile a piacere
- Rectangular bar - cuttable to size
- Eckige Stange beliebig Kürzbar.

L = 1200 mm IL IX NO
L = 1500 mm CF BV OL OS RM BI



B-225-R

- Attacco a vetro snodato per barra di supporto quadra.
- Glass fitting with swivel clamp.
- Drehbarer Glasanschluss.

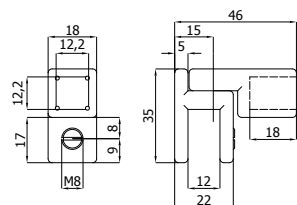

B-224-R

- Attacco a muro snodato per barra di supporto quadra.
- Wall fitting with swivel clamp.
- Drehbarer Wandanschluss.

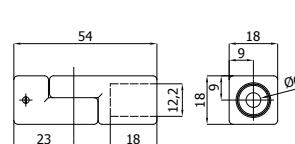

B-222

- Attacco a vetro in linea passante per barra quadra.
- Glass connector through with adjustable positioning on the bar.
- Glasanschluss mit Durchgangsbohrung.

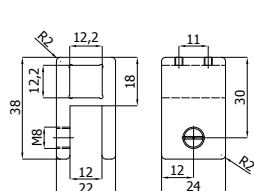

xme718



P798



F3664

B-226

- Supporto centrale per vetro fisso
- T-connector with glass clamp
- T-Stück Glas-Stange mit Glasanschluss

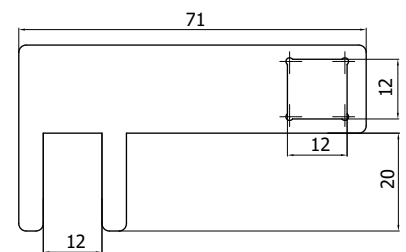
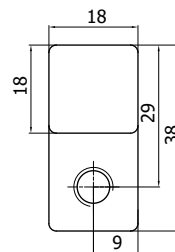
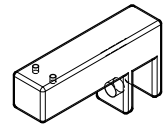

ACCESSORI

ACCESSORIES
ZUBEHÖRE

ATELIER *delle*
FINITURE



P-017

- Profilo gocciolatoio.
- *Splash guard profile.*
- *Schwallschutz Profil.*

L = 2500 mm

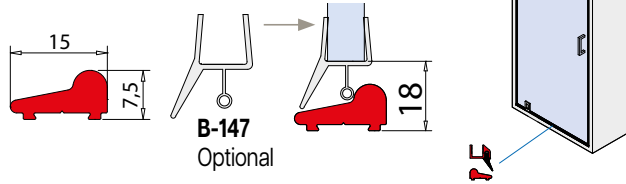

Panoramica prodotto
Product overview



P130

Listino
Price list



F1847



BX-PT3-C57

- Angolo 90° lato entrata doccia per profili P-017.
- *Joint 90° corner entry for profiles P-017.*
- *90° Verbindung Eckeinstieg für Profile P-017.*

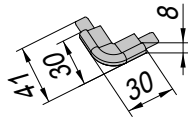

BX-PT3-C60

- Coperchietto finale per profili P-017, destro e sinistro.
- *Endcap for profiles P-017, left and right.*
- *Endkappe für Profile P-017 Links und Rechts.*

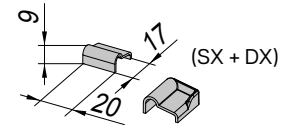

DIV-050

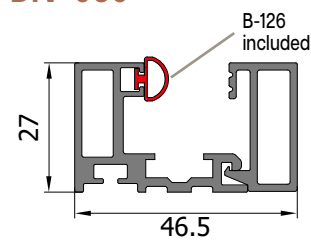

- Profilo a scatto per vetri fissi
- *Clip-on profile for fixed panels*
- *Klipsprofil für Festverglasungen*

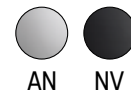

L = 3000 mm

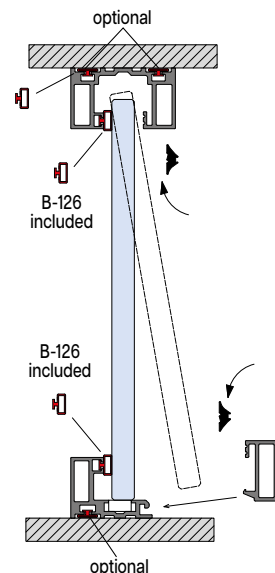

VP-016

- Per vetro 8 mm
- *For glass 8 mm*
- *Für Glas 8 mm*

VP-017

- Per vetro 10 e 13,5 mm
- *Per 13,5 mm rimuovere B-126*
- *For glass 10 and 13,5 mm*
- *For 13,5 mm remove B-126*
- *Für Glas 10 und 13,5 mm*
- *Für 13,5 Entfernen Sie B-126*

VP-018

- Per vetro 12 e 12,76 mm
- *For glass 12 and 12,76 mm*
- *Für Glas 12 und 12,76 mm*

xme658



P191



F1865

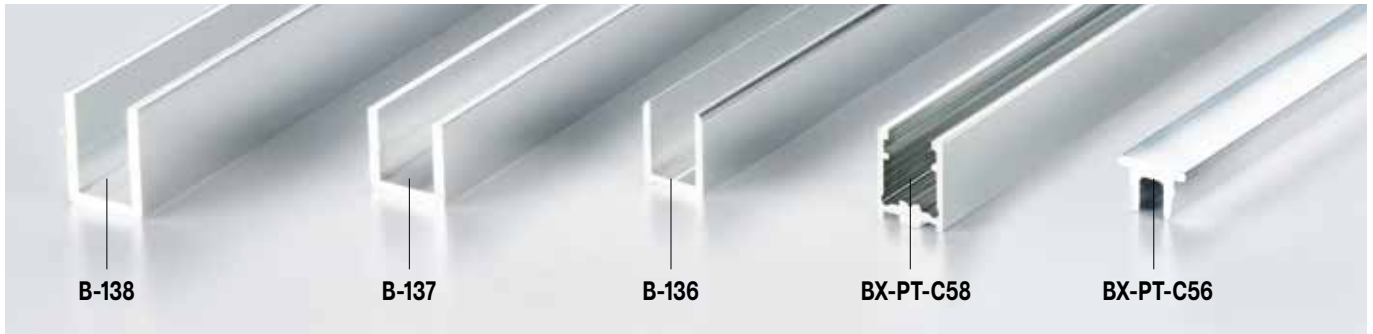

B-138

- Canalina spigoli vivi.
- Sharp corner "U" channel.
- U-Profil Aluminium.
- L = 3000 mm

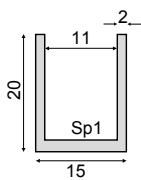

B-137

- Canalina spigoli vivi.
- Sharp corner "U" channel.
- U-Profil Aluminium.
- L = 3000 mm

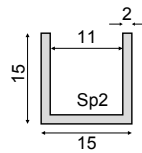

B-136

- Canalina con bordi arrotondati.
- "U" channel.
- U-Profil Aluminium.
- L = 3000 mm

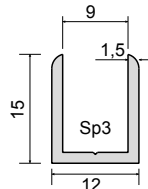

BX-PT-C58

- Canalina con bordi arrotondati.
- "U" channel.
- U-Profil Aluminium.
- L = 1500 / 3000 mm

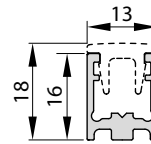

BX-PT-C56

- Coperchio per profilo a terra BX-PT-C58 per tratto entrata doccia.
- Cover profile for floor profile BX-PT-C58, shower entry.
- Profilabdeckung Bodenprofil BX-PT-C58, Duscheinstieg.
- L = 1500 / 3000 mm

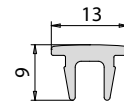

xla367c-2

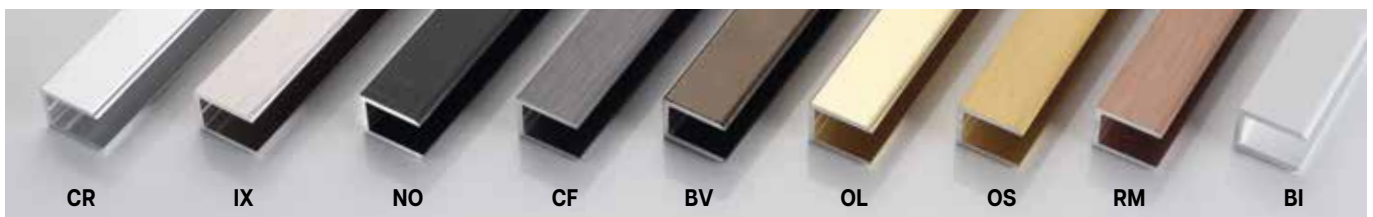

POR-0400V

- Maniglione singolo con biadesivo
- Pc pullhandle with self-adhesive fixing
- Stück Stosgriff selbstklebend

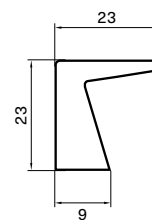

L = 240 mm



MID-10-INC

- Paio maniglie con biadesivo
- Pair handles with self-adhesive fixing
- Paar Griffe selbstklebend

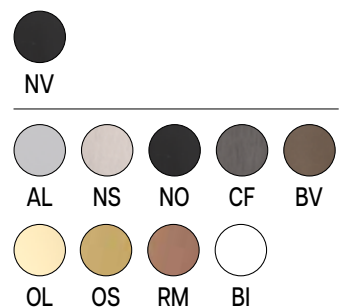
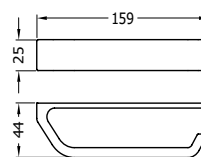

ACCESSORI

ACCESSORIES
ZUBEHÖRE

ATELIER *delle*
FINITURE

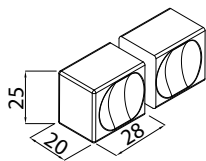

Panoramica prodotto
Product overview



P182

Listino
Price list



F1876

B-196

- Coppia pomoli 25 x 28 mm.
- Pair of doorknobs 25 x 28 mm.
- Paar Türknöpfe 25 x 28 mm.

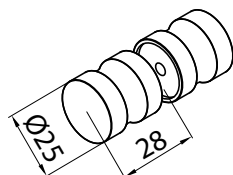
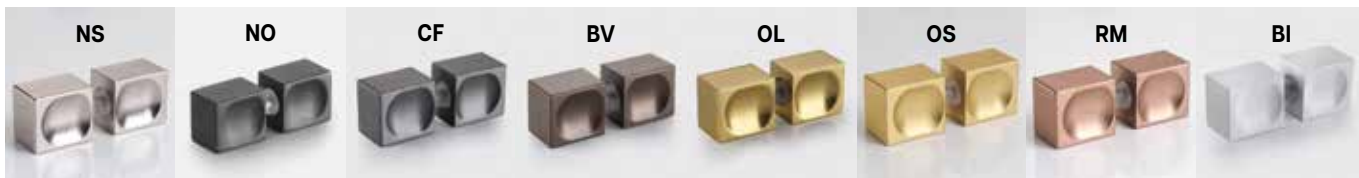

V-024-25

- Coppia pomoli Ø 25 mm.
- Pair of doorknobs Ø 25 mm.
- Paar Türknöpfe Ø 25 mm.



ACCESSORI

ACCESSORIES
ZUBEHÖRE

ATELIER *delle*
FINITURE

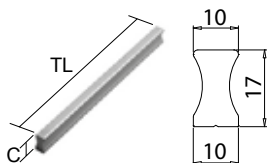

TL = 260 mm

Panoramica prodotto
Product overview



P640

Listino
Price list



F2892

POR-0408V

- Maniglione singolo con biadesivo
- Pc pullhandle with self-adhesive fixing
- Stück Stossgriff selbstklebend

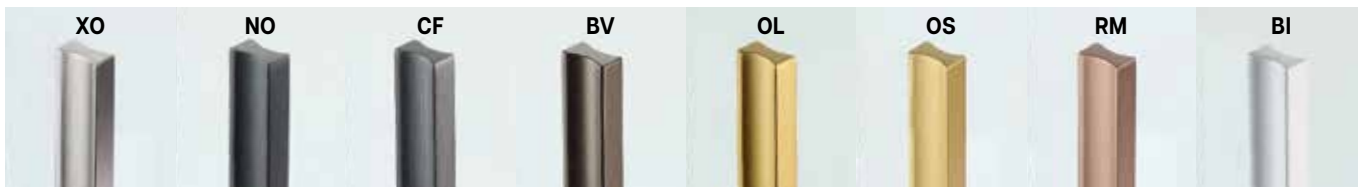

TL = 206 mm
A = 192 mm

Panoramica prodotto
Product overview



P642

Listino
Price list



F2890

SQUARE15

- Maniglione. Materiale: Alluminio
- Pullhandle. Material: Aluminium
- Stossgriff. Material: Aluminium



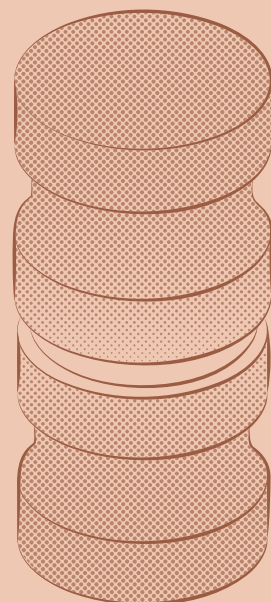
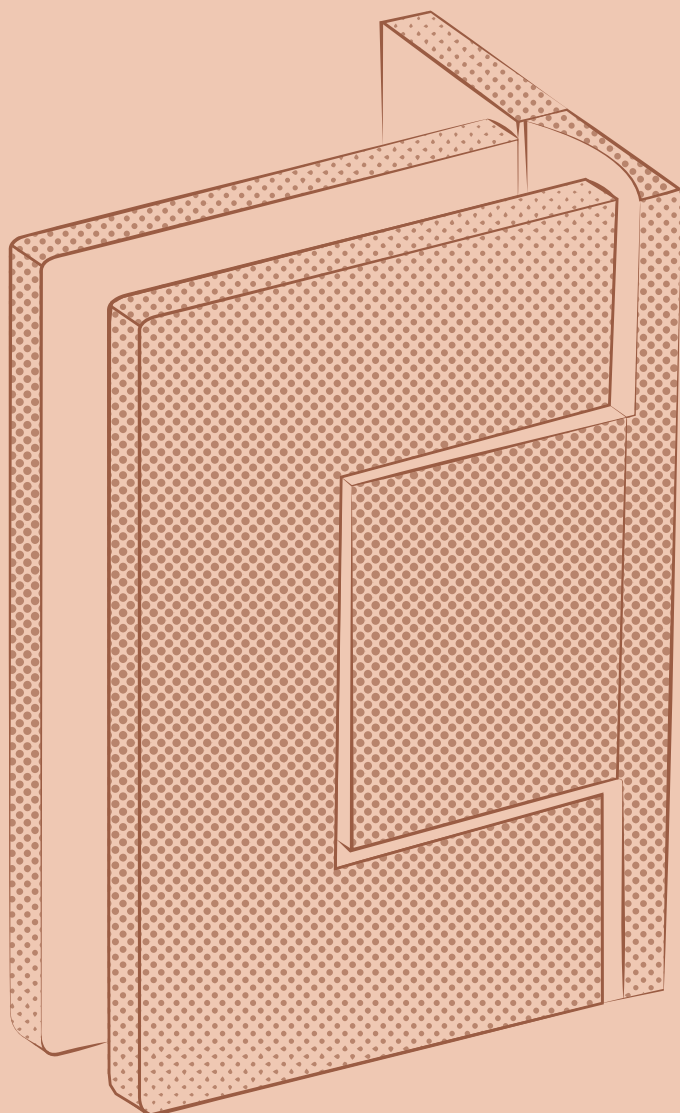
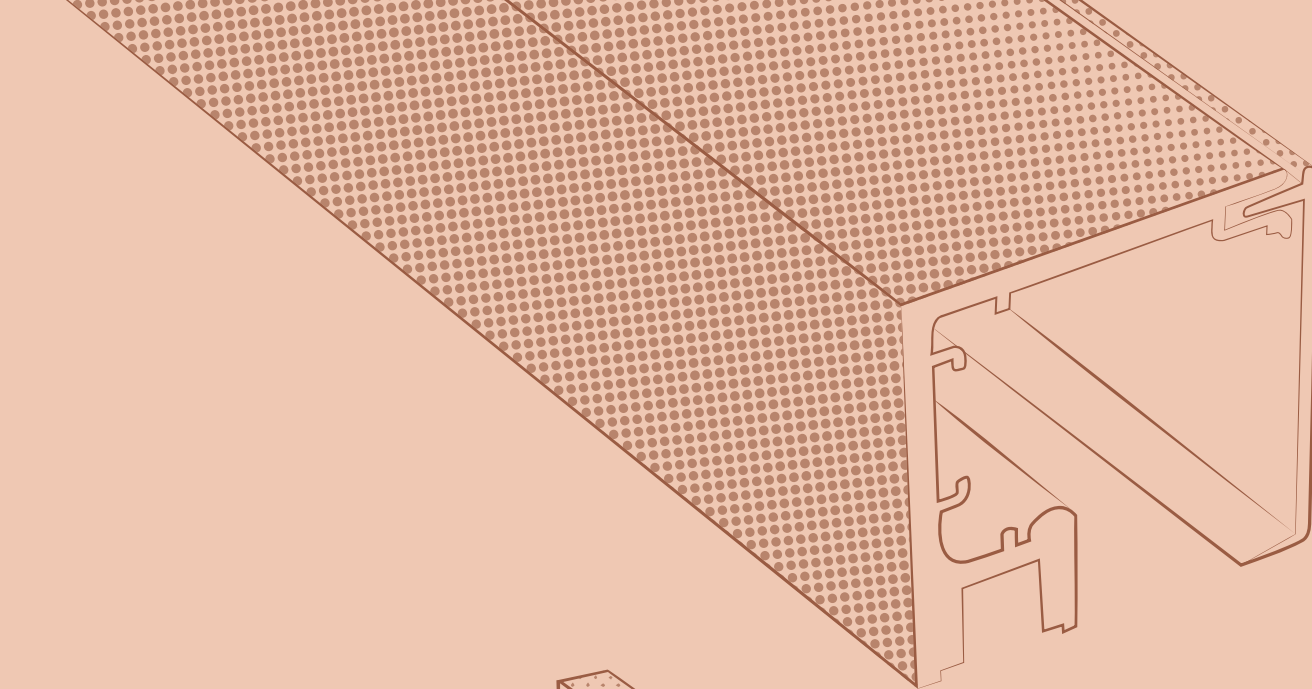

METALGLAS
BONOMI



METALGLAS BONOMI srl
Via Montini, 106/A
25065 Lumezzane S.A. (Brescia) Italy
Ph. +39 030829910
www.metalglas.it - info@metalglas.it